

Using Water Heaters for Radiant Heat

Gas-fired water heaters can provide reliable, efficient space heating as well as domestic hot water



SuperStor's Voyager water heater works well in dual-purpose applications, for both drinking water and space heating. Voyager offers a built-in heat exchanger, but the author prefers to use an external unit, shown preassembled with expansion tanks and circulators in the photo above. The heat exchanger is fully insulated and is located between the tank and the red and blue heating loop manifold (left).

Six years ago, I nervously installed my first hot water heating system fired not by a boiler, but by an ordinary gas-fired storage water heater. It went in easily, worked well, and was cheap. Since that time, I've installed at least 30 such systems, both perimeter baseboard and radiant floor applications, and have had no complaints so far.

Water Heater Myths

Most heating guys will tell you that you can't use the lowly water heater to fire your hydronic heating system, but they often don't give any good reasons to back up their claims other than they've always used boilers. Or they'll tell you water heaters are unsafe, inefficient, and expensive hydronic heat sources. I say that not only will a water heater work, but many times it's also the best as well as the least expensive way to heat a project. Today, only a minority of our jobs

by **Bill Clinton**

Efficiency of Water Heater vs. Boiler

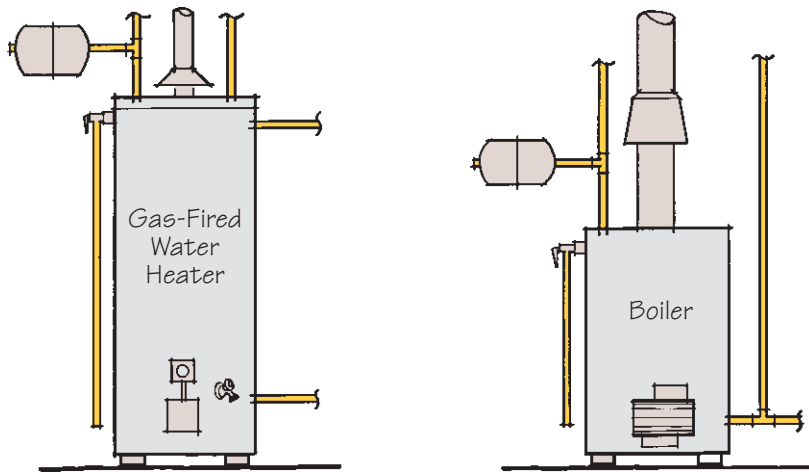

Rating Label:	60%
Steady-State Efficiency Gain (when used for heating, water heater operates more frequently at higher steady-state efficiency):	+8%
Actual Efficiency:	68%

Rating Label:	83% AFUE
Jacket Loss (heat dumped into boiler room):	-5%
Vent Hood Loss (heat dumped into boiler room):	-10%
Zone Loss (boiler is less efficient when only one zone calls for heat):	-10%
Actual Efficiency:	58%

Figure 1. Even though conventional boilers might have a higher efficiency on the rating label, they can still cost more to operate. A boiler's AFUE (annual fuel utilization efficiency) rating makes the assumption that heat lost through the jacket and spilled out the draft hood is dumped into the living space. If the boiler is in an unfinished basement or garage, however, this heat is actually lost. Water heater efficiency ratings, on the other hand, assume near-zero efficiency when the heater is on standby. Averaged in, this lowers the unit's efficiency rating. Adding a heating load, however, increases average efficiency because the tank operates more frequently at its higher steady-state combustion efficiency of 76% to 80%.

get a boiler — the rest get water heaters, with no apologies.

Let's separate fact from fiction. Here are the most common objections I hear to using water heaters instead of boilers and how I answer each of them.

MYTH 1 Water Heaters Can't Produce Hot Enough Water

Typical boiler systems use a design temperature of 180°F or higher, which produces scalding hot surface temperatures at cast radiators and convector units and is too hot for radiant floor applications. Lower water temperatures are becoming more common because

they are safer for children and and produce a more even and comfortable heat.

However, simply turning down the boiler temperature doesn't work, because regular-efficiency boilers can condense flue gases into a corrosive liquid at return water temperatures of 130°F or lower. To make regular boilers work properly in modern systems often means adding expensive mixing controls to lower the output water temperature.

Water heaters, on the other hand, are perfectly happy being fed 55°F supply water and chugging along at 110°F to 140°F — perfect for radiant floors, and more than adequate for many baseboard and panel radiator applications. The sys-

tem designer may have to increase the size of the radiators to account for the lower water temperature. A good rule of thumb is to lower the output 10% for each 10°F drop, so 140°F water would require about 40% more baseboard than 180°F water.

Thermal stress eliminated. Modern hydronic systems tend to be multiple zone, and it's common for only one zone at a time to call for heat. The result can be a flow rate so low that the temperature increase across the boiler greatly exceeds what the boiler was designed for (usually about 30°F). Hotter areas in the boiler experience greater thermal expansion than cooler areas. When inlet and outlet temperatures are too far apart (often 80°F and more in this situation), stresses build up and can crack or rupture the boiler. I've seen a number of boilers destroyed this way.

A water heater, on the other hand, doesn't care about flow rates. It's perfectly happy with a low flow, and is designed to handle incoming water temperatures of 55°F.

MYTH 2 Water Heaters Are Less Efficient Than Boilers

Rating labels would lead you to believe a boiler will make for lower operating costs than water heaters, but this isn't true (see Figure 1). The efficiency you get from a boiler or a water heater relates more to how you use it than what's on the label. For example, under normal circumstances a water heater experiences "standby" losses — heat wasted up the chimney — every minute that you're not using hot water. A label rating of 55% overall efficiency might be an average of 80% during the combustion cycle and 0% during standby. If you've already got a water heater in place, adding a space heating function taps into the higher steady-state (operating) efficiency while not adding to the dismal standby efficiency. This means that the new average is in the same ballpark as you'd get from a conventional boiler. It gets even better than that, because boilers become less efficient than rated when they're under-utilized — for example, when only one

Water Heater Dedicated for Heating

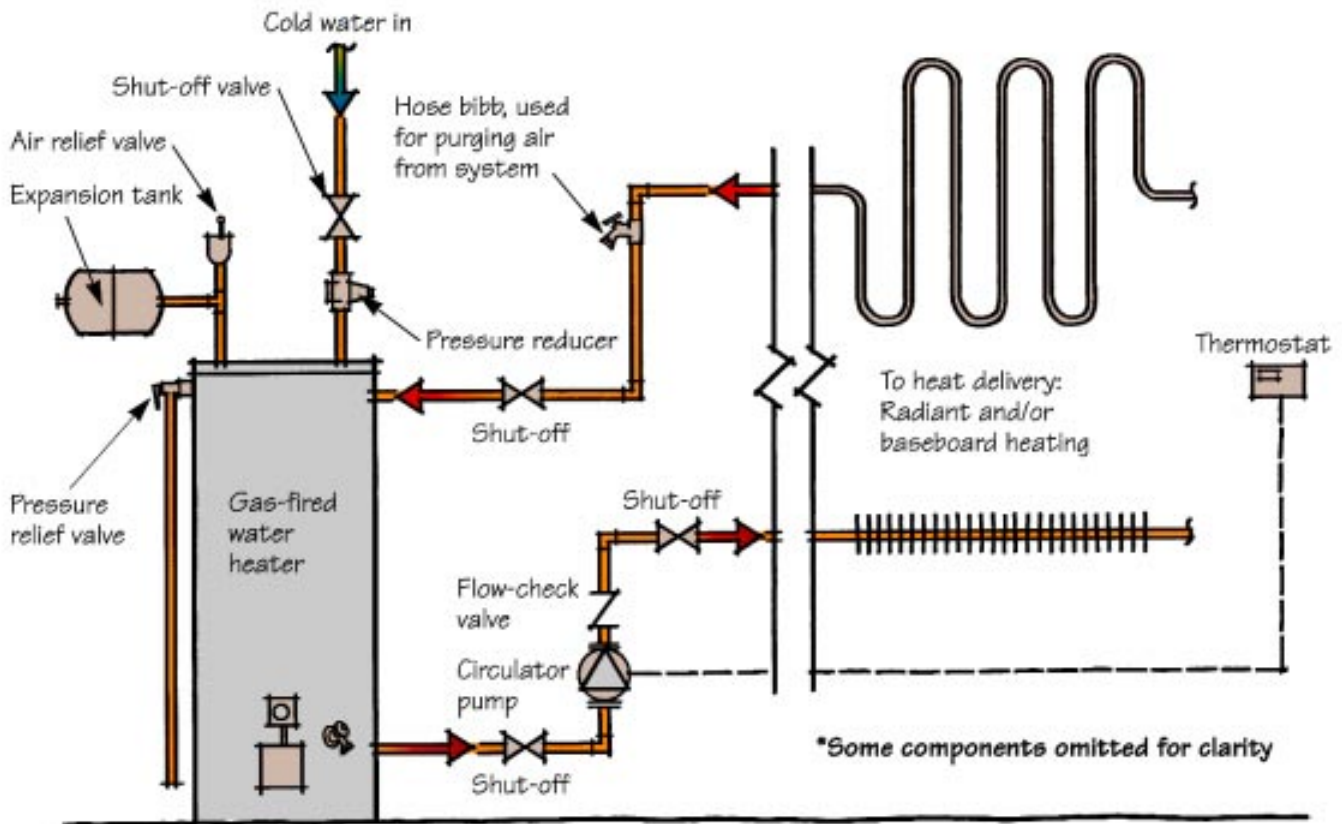

Figure 2. A dedicated setup is the simplest, least expensive way to use a water heater for space heating. The author always uses a unit with side taps for easy installation. The pump is installed at the bottom to avoid air lock.

zone out of many is calling for heat, or on a mild winter day with solar gain, or when the boiler is oversized, as they commonly are. Compared with those situations, a water heater can actually cost less to operate, even though its rating may be lower.

MYTH 3 Water Heaters Don't Last and Are Unreliable

Storage water heaters are as reliable as anything else in the mechanical world — but they do require a little maintenance. Flushing out sediment, checking relief valves, and replacing the sacrificial anode will assure years of trouble-free operation. The sacrificial anode is especially important. It's there to protect the tank when the impurities in the water create a galvanic reaction. If there's no

anode to attack, the corrosion will attack the tank instead, shortening its life.

Water heater maintenance is much less expensive than yearly boiler checks, and properly piped with isolation valves and unions, a storage water heater is easy to replace when it does go bad.

MYTH 4 Water Heaters Are Unsafe

Out of the box, water heaters have more safety controls than the typical boiler. Horror stories where water heaters used as boilers blow up or blast off through the roof are almost always the result of improper installation or of someone doing something nutty like plugging the relief pipe. Properly installed, storage water heaters are as safe as any other heating appliance in my opinion.

Piping a Water Heater for Space Heating: The Basic System

There are several ways to hook up water heaters to supply a heating system. The method you use will depend on balancing initial cost with system life and operating efficiency.

If all you need to do is add a warm floor to a bathroom or some baseboard convectors in a small den and you are willing to live with lower efficiency, the least expensive method is to install a dedicated "hardware store" quality water heater with only minimal controls: A pump, backflow preventer, and expansion tank are all that are needed (Figure 2). The circulating pumps used with boilers require a separate "pump controller," which is a relay that turns the pump on and off in response to the thermostat. Many basic systems will be

Dual-Purpose Water Heater

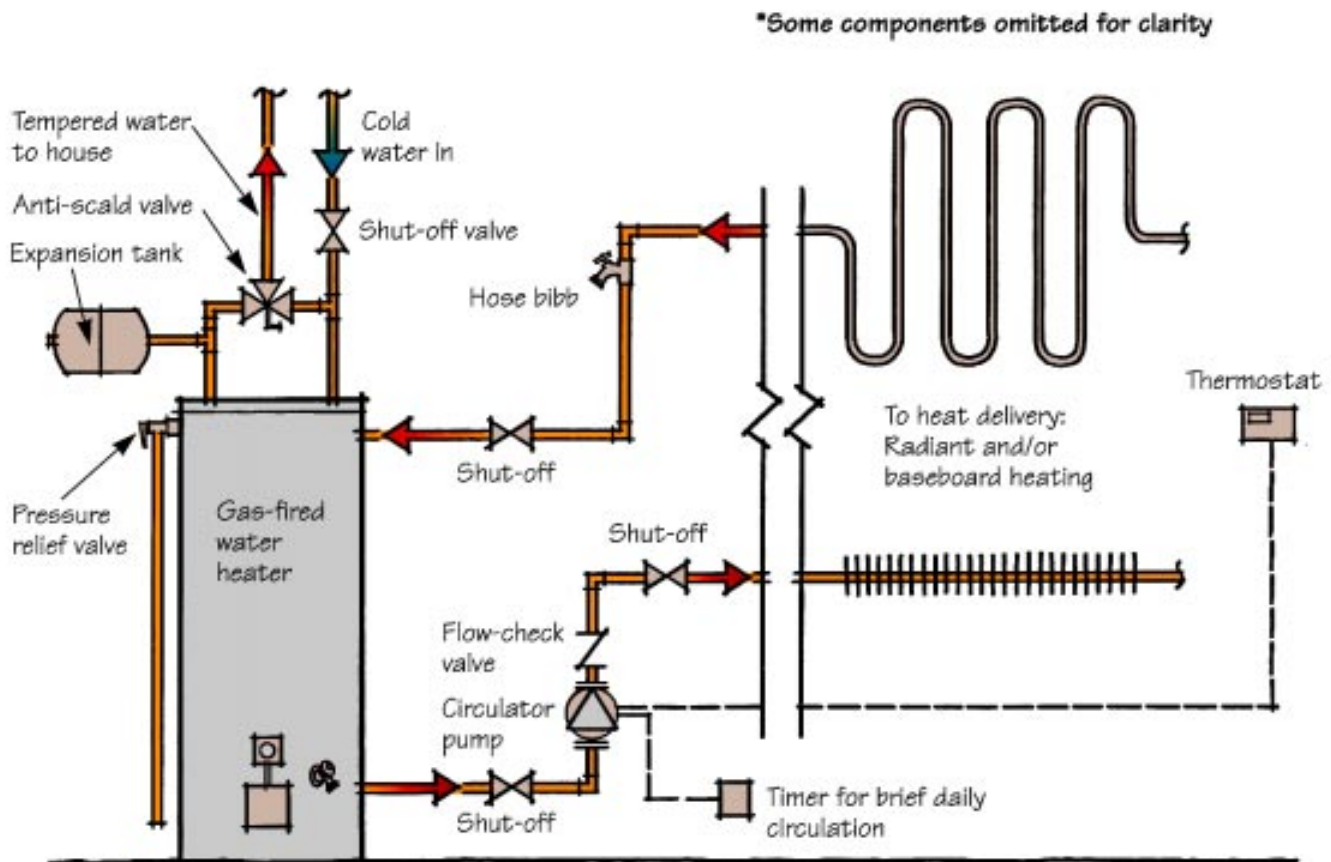

Figure 3. The dual-purpose setup provides both space heating and domestic water heating. The timer on the circulator shunts water through the heating loop at regular intervals to prevent the growth of bacteria that might take place if the water were stagnant.

single zone, so consider using a pump with a built-in relay to save the additional cost, such as the Taco “zone priority circulator” (Taco Inc., Cranston, R.I.; 401/942-8000).

We install the pump at the bottom of the tank to minimize the problem of “air locking,” which occurs when the dissolved oxygen in the water forms bubbles that rise and prevent the water from circulating.

To power the pump, we simply attach a flexible “pigtail” and plug it into a nearby outlet. The thermostat hooks directly to the relay terminals on the pump. If the water heater is below the heating units, you’ll also need a check valve to prevent thermosiphoning — the tendency of the system to circulate by itself as the hot water rises.

Because this system will be circulating domestic drinking water at line pressure through the heating system, be sure to check with local authorities for code compliance, and only use components rated for use with potable water to limit corrosion and scaling. These problems occur when the oxygen dissolved in the domestic water comes into contact with carbon steel or iron components in the system, or with dissolved minerals such as calcium. For that reason, it’s necessary to use only brass, copper, stainless steel, or approved plastic components in systems that are in contact with potable water.

Dual-Purpose Systems

While it works fine to use a water heater for space heating alone, it

makes sense to design a dual purpose system — one that’s capable of heating domestic water as well. If you use a high-quality sealed-combustion tank, such as a Bradford White TTW2 (Bradford White Corp., Ambler, Pa.; 800/538-2020), the real-world operating efficiency of this setup is close to 85%, better than just about anything else out there. This approach makes sense because of lower operating costs and more efficient use of floor space. There are two types of dual-purpose systems in use — those with heat exchangers and those without.

No Heat Exchanger

This system is nothing more than an expanded version of the basic system. The water tank provides domestic water

Dual-Purpose System With Heat Exchanger

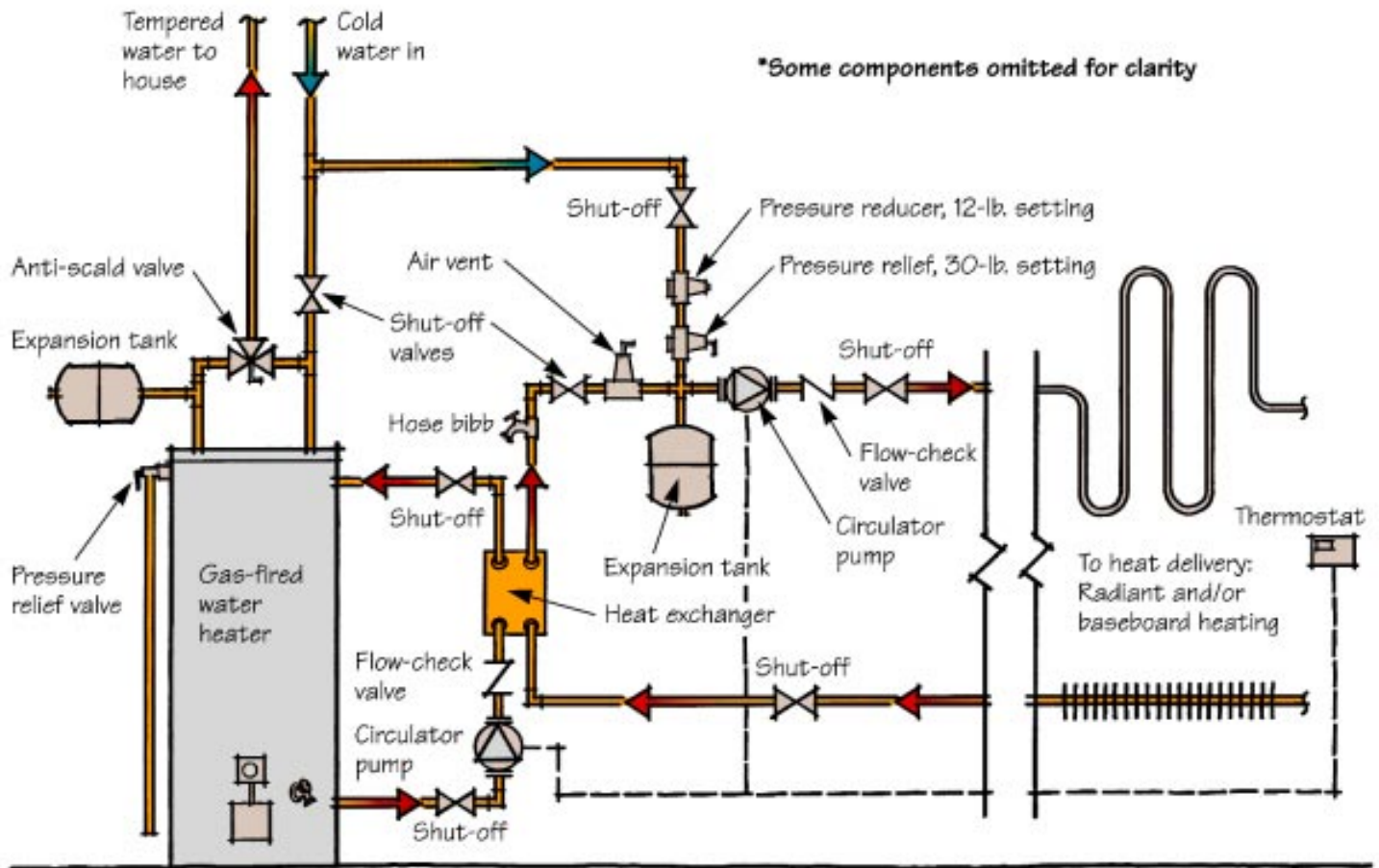

Figure 4. The author's favorite system uses an external heat exchanger to isolate the heating loop from the home's drinking water. The tank temperature is set high enough to meet the heating demand, while the domestic water is tempered for safety.

to the building as normal, but a zone or zones are added for space heating (Figure 3). Tread with caution — many local authorities frown on these systems, and with good reason. During the summer months, the water in the heating zones gets stagnant and can grow dangerous bacteria. If you install a dual-purpose system with no exchanger, always install a timer to circulate fresh water into the heating zones for a few minutes every day.

Because these are not sealed systems, all components are at risk of corrosion, so again be sure to use only those approved for use in potable water systems.

Heat Exchanger Systems

Heat exchangers keep the potentially stagnant heating water completely sepa-

rate from the domestic water system. In a heat-exchanged system, the space heating side is set up almost exactly as it would be if you were using a conventional boiler as the heat source (Figure 4). The hot water in the tank warms the metal in the heat exchanger, which in turn warms the water in the heating zones.

There are two types of exchangers, the external-mount flat plate style and the internal double-wall coil (Figure 5). Given the choice, I would always opt for a generously sized flat-plate stainless-steel heat exchanger mounted on the outside of the water heater. The flat-plate exchangers transfer heat more efficiently than the double-wall coil types, so they allow for lower water temperatures on the domestic side.

Efficiency aside, I prefer external-mount exchangers for practical reasons. Since the exchanger is likely to outlive the water heater, or vice versa, it makes sense to me to keep them separate. It's like having separate stereo components — if one thing breaks, that's all you have to fix. I always install all the components with isolation valves and unions for easy servicing.

Nevertheless, some codes and some inspectors require a double-wall exchanger, which is usually built in as part of the water heater, as in Bradford White's Combi-Cor. The double-wall exchanger provides an extra layer of protection from contamination should the exchanger fail. But double-wall exchangers also create a great deal of resistance to flow and lower transfer efficiency, so it's

often necessary to use high capacity pumps and higher working temperatures. The Combi-Cor, for example, normally has to be run as high as 180°F degrees to make up for the extra resistance.

Scald Protection

Nine times out of ten, using a water heater for heating means cranking up the water temperature to unsafe levels for bathing or laundry, so anti-scald valves and other tempering devices will be necessary for safety. The tempering valve works by mixing the outgoing hot water with cold line water to lower the overall temperature (Figure 6). Think of

it as a secondary thermostat on the domestic water side.

Choosing a Water Heater

For a low-budget system without a heat exchanger, any standard water heater will do as long as the Btu output is enough to cover the heating load. I would always choose one with an extra tap on the side (in addition to the tap on top for the pressure relief valve), because it makes the piping a lot easier. The Bradford White TTW2 meets this criteria.

High-efficiency units. For a heat-exchanged system, I prefer using a high-end sealed combustion water heater

with an external heat exchanger. There are a couple of ultra-high efficiency water heaters on the market that are ideal for hydronic applications. The Polaris (American Water Heater Group, Dallas, Texas; 800/937-1037) and SuperStor's Voyager (Heat Transfer Products, East Freetown, Mass.; 800/323-9651; 508/763-8071 in Mass.) both use stainless-steel tanks with sealed condensing burners. These units draw outside air for combustion and operate at efficiencies that rival even the highest-efficiency (and highest-priced) boilers. The downside is their initial cost, which, starting at around \$1,500, is ten times the cost of a cheap hardware store water heater. Still, these are appliances that will probably last for the life of the mortgage, and the lower operating costs pay back quickly. In a northern climate (6,000 degree days or more), the homeowner might realize a savings of \$300 to \$400 per year on space heating and another \$150 for domestic water heating. (Of course, the final savings will depend on the heating climate and fuel costs in your area.)

If I'm installing a heat-exchanged system but the budget is limited, I pipe the space heating side exactly the same way as I would with a high-end water heater, but substitute a conventional "hardware store" unit like the Bradford White TTW2. We install them with shutoffs and unions so the homeowner can easily retrofit a higher-efficiency water heater later.

When the local building official demands the extra protection of a double-wall heat exchanger, I go for a Combi-Cor, with its built-in coil exchanger. It's easy to pipe, and only requires one pump instead of the two that are needed with an external exchanger. The Combi-Cor's drawbacks are that it has to operate at very high temperatures to get substantial space heating output, and that the components are not separately replaceable — when the heater tank goes, the exchanger goes with it. 

Bill Clinton has been a plumbing and heating contractor for 25 years, and operates Bay Hydronic in Northern California.



Figure 5. This flat plate heat exchanger (left) is adequate for heating a 4,000-square-foot house in the author's climate (75,000 Btu/hr.). Where code officials insist, the author uses a Combi-Cor unit (right), which has an internal coil exchanger. The coil's double wall offers secondary protection against contamination of the drinking water by the heating fluid.



Figure 6. When water heaters are used for both space heating and domestic water, the domestic side must usually be mixed with cold water for safety's sake. A mechanical tempering valve is a simple way to do this.

